

# IA 120

## Principles of industrial sensors



### Description

- **familiarisation with key sensors: mode of operation and application**
- **all components are protected in a sturdy case**

This training kit can be used to investigate a selection of different sensor types commonly used in industrial automation: optical, capacitive and inductive proximity switches to record displacement and proximity. These sensors are mounted on a base plate with the relevant accessories. The trigger distance is determined by moving the sensor holder. The base plate is provided with a scale for this purpose.

A separate supply unit powers the sensors and displays the switching state by way of light-emitting diodes.

### Learning objectives/experiments

- **mode of operation and application of different sensors**
  - ▶ one-way photoelectric barrier
  - ▶ reflex photoelectric barrier
  - ▶ inductive proximity switch
  - ▶ capacitive proximity switch
  - ▶ reflex photoelectric proximity switch, infrared
  - ▶ reflex photoelectric proximity switch, red light
  - ▶ limit switch
  - ▶ reed contact

# IA 120

## Principles of industrial sensors

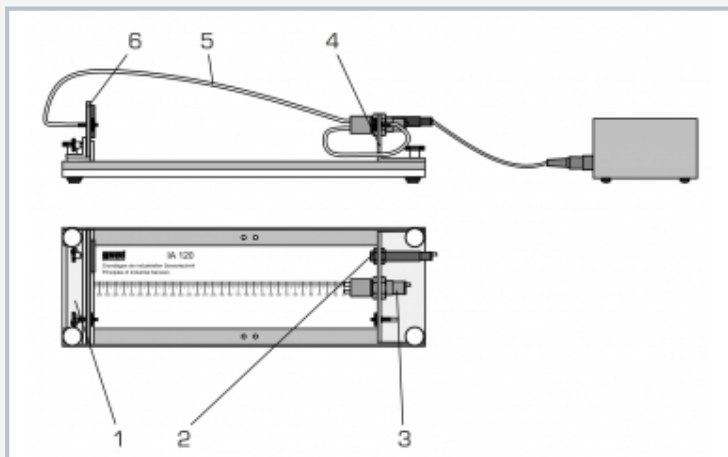

1 slide, 2 reflex photoelectric barrier, 3 light guide, 4 sensor holder (interchangeable), 5 fibre-optic cable, 6 reflector holder

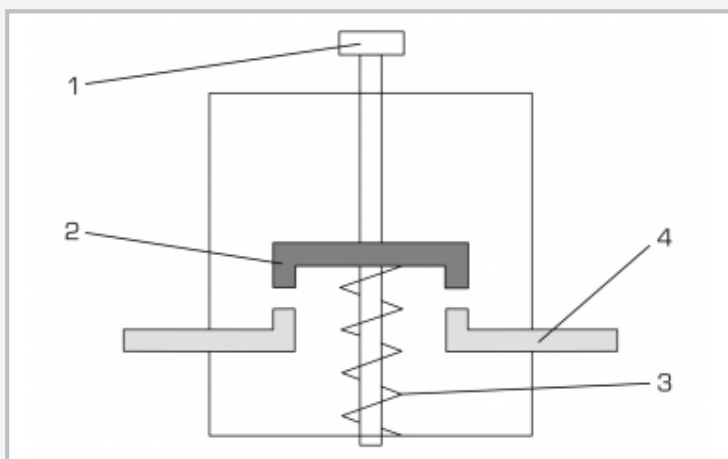

Electric limit switch: 1 momentary-contact switch, 2 switching element, 3 spring, 4 connection

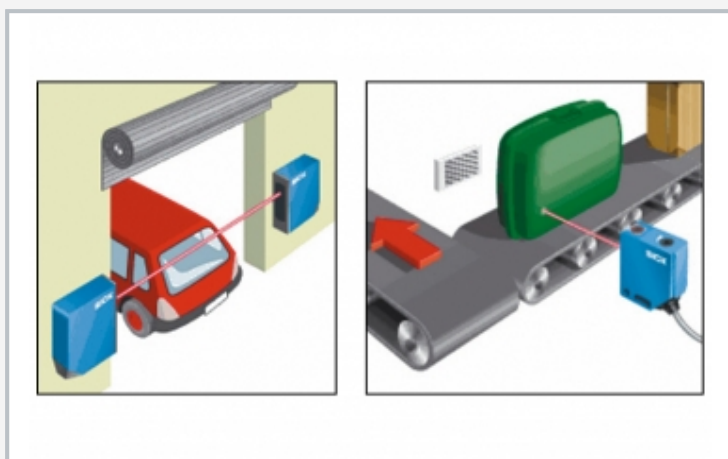

Left: transmissive photoelectric switch, right: reflex photoelectric switch

### Specification

- [1] training kit for familiarisation with position and displacement sensors
- [2] base plate with scale
- [3] sensor supply unit with 4 light-emitting diodes
- [4] sensors mounted on adjustable fixture
- [5] 5 measuring plates
- [6] all mountings and components housed in aluminium storage case

### Technical data

Measuring plates, LxW: 145x70mm

- aluminium sheet: d=2mm, smooth, black
- steel sheet: d=2mm, textured, matt black
- steel sheet: d=2mm, smooth, silver
- plexiglas plate: d=5mm, transparent
- plastic plate: d=5mm, smooth, white

Gauge screw: 0...25mm

Sensors

- reflex photoelectric barrier: pnp, dark-switching
- light guide: pnp, dark-switching
- reflex photoelectric proximity switch: pnp, light-switching, 5...150mm
- photoelectric proximity switch: pnp, light-switching
- inductive proximity switch: pnp, NO contact
- capacitive proximity switch: NO contact, 1...8mm
- limit switch: 1 NO contact, 1 NC contact
- reed contact: switching distance: 5mm, max. 1W at 24V

Power supply

- output voltage: 3...12VDC, graduated
- output current: 1000mA

230V, 50Hz, 1 phase

230V, 60Hz, 1 phase

120V, 60Hz, 1 phase

UL/CSA optional

LxWxH: 510x410x200mm (case)

LxWxH: 460x150x27mm (base plate)

LxWxH: 160x85x140mm (sensor supply)

Total weight: approx. 14kg

### Scope of delivery

- 1 experimental unit, complete
- 1 case
- 1 set of instructional material